



CONTRACT RIDER: THE SHANGRI-LA CHINESE ACROBATS Revised 03/15/2010
The Shangri-La Chinese Acrobats® are produced by

IAI Presentations, Inc.

www.iaipresentations.com

(805) 474-8422: PHONE

(805) 474-8426: FAX

TECHNICAL RIDER: THE SHANGRI-LA CHINESE ACROBATS®

This technical rider, dated March 15, 2010, supersedes all previous riders.

THE FOLLOWING RIDER IS AN INTEGRAL PART OF THIS CONTRACT. PLEASE READ IT CAREFULLY. IF YOU HAVE ANY QUESTIONS OR PROBLEMS WITH PROVIDING ANYTHING IN THE RIDER, PLEASE CALL THE PRODUCTION OFFICE IMMEDIATELY.

THE COMPANY

THE SHANGRI-LA CHINESE ACROBATS® are from The People's Republic of China and consists of about 15 people, including our American crew. Their tradition is to do everything together; the troupe lives as a family unit. If there is a social function, they should all be invited; it is considered impolite to single out certain members for special treatment. It is extremely important that all communication with the group or an individual regarding social or business arrangements be conducted through the production office at IAI Presentations, Inc. (contact information above and in Item R, page 12 of this rider). Please give the production office coordinator all the information either in writing or over the telephone so it can be translated and communicated accurately to the members of the troupe and the technical director.

Due to the nature of the acts and the possibility of injury, the Chinese group leaders may have to change the order of the acts from performance to performance and even, although rarely, while the performance is in progress. Please understand that these are consummate professionals, with many years of experience, who will always give their best effort regardless of the circumstances. If an act must be moved, some refocusing of specials may be required, possibly at the last moment. Please advise your technical staff that should lighting or other staging changes have to be implemented, they are made for the safety of the performers and the audience, and are in no way arbitrary. Our technical director will arrive with the troupe to begin setting up the necessary rigging and focusing of specials. The stage manager and the acrobats will decide on the best position for each act. However, the final determination as to where and/or whether an act will be performed on stage rests with the performers.

In China, the performers do everything themselves and technical crews in America may find this disconcerting. The Chinese are fully involved in all types of rigging and counterweight operations. They pack, unpack, load, repair, and maintain all of their own equipment. Please make your technical staff prepared for this work ethic. For everyone's good, please have your crew check that they have all of their equipment prior to the completion of the load-out. Remember, things get packed very quickly so make sure your crew is aware of this!

A. STAGE DIMENSIONS

THE SHANGRI-LA CHINESE ACROBATS® requires a stage with a proscenium opening of approximately forty feet wide and thirty-six feet deep (*from proscenium to back curtain, or cyclorama*) and a proscenium height of twenty-six feet. These are approximate sizes and, if not available, then please discuss your stage size with our Production Office. We can most often work in smaller stage dimensions, so please let us know if you have any concerns on your particular situation. The floor should be even, smooth, and free of any obstructions which might be hazardous to the performers. The stage floor must be swept and damp mopped by the local crew prior to each performance and at the intermission. The production carries a carpeted mat which must be vacuumed by local crew prior to each performance and at the intermission.



CONTRACT RIDER: THE SHANGRI-LA CHINESE ACROBATS Revised 03/15/2010

B. CREW CALL

Please Note: All lighting instruments are required to be hung, circuited, colored, and focused before the company arrives.

Providing all electrics and draperies have been properly hung, and other stage preparations as noted herein have been **completed prior to the production's arrival**, the load-in and set-up should take about three hours and load-out requires approximately one hour or less.

- **Load-In and Load-Out**

Minimum Crew Call:

- 1 – Lighting Technician
- 1 – Sound Technician
- 1 – Stage Hand
- 2 – Follow Spot Operators

The Shangri-La Chinese Acrobats® do not require any wardrobe personnel; however, any laundry rooms should be unlocked and available for use from the time of the company's arrival until they depart. Laundry detergent and fabric softener should be made available to the performers if laundry facilities are open to them at your venue.

- **Show Run**

Minimum Crew Call:

- 1 – Lighting Technician
- 1 – Sound Technician
- 1 – Stage Hand
- 2 – Follow Spot Operators

(The above crew numbers may be subject to change due to local crew availability.)

As noted above, The Shangri-La Chinese Acrobats® have a very fast load-out: often less than one hour. **All Shangri-La Chinese Acrobats® equipment will be struck from the stage and loaded into their transport before any house restore can begin.**

Please Note: Local union agreements may have an impact on the above numbers.

The PRODUCTION cannot be responsible for any damage to, any claim for, or any loss of anything backstage if appropriate venue stagehands are not on-site for the load-in, run of show, and load-out.



CONTRACT RIDER: THE SHANGRI-LA CHINESE ACROBATS Revised 03/15/2010

C. LIGHTING

The Shangri-La Chinese Acrobats® Lighting Plot as supplied on page 14 of this rider can be described as follows:

- A four-color wash from FOH (*Rx33, Rx26, Rx67, and Rx12*).
- A four-color wash from “on stage” pipe ends. (*Rx33, Rx26, Rx67, and Rx12*).
- A three-color wash (*Rx26, Rx67, and Rx12*) from the “on stage” electrics.
- A three-color cyclorama wash (Primary Red, Blue, and Green).

Lastly, running lights are required in the upstage crossover, and stage left and right wings.

1. FLEXIBILITY

The Shangri-La Chinese Acrobats® are not locked into the exact instruments listed on the plot, however, bright, even washes with high coverage are essential to the show. If the washes are bright and full, the company will be satisfied. Please contact the production office or the company’s technical director about any changes the venue needs to make.

2. CONTROL

The company will use house control console.

3. FOCUS

- **Front of House**

The FOH lighting is a straight-on, four-color wash divided into downstage and up-stage focuses. See Light Plot on Page 14 for FOH Odd and Even Group Numbering.

Odd groups: From the downstage edge of the stage to mid-stage

Even groups: Overlap the downstage wash and cut up-stage to the base of the cyc (*or, off teaser*).

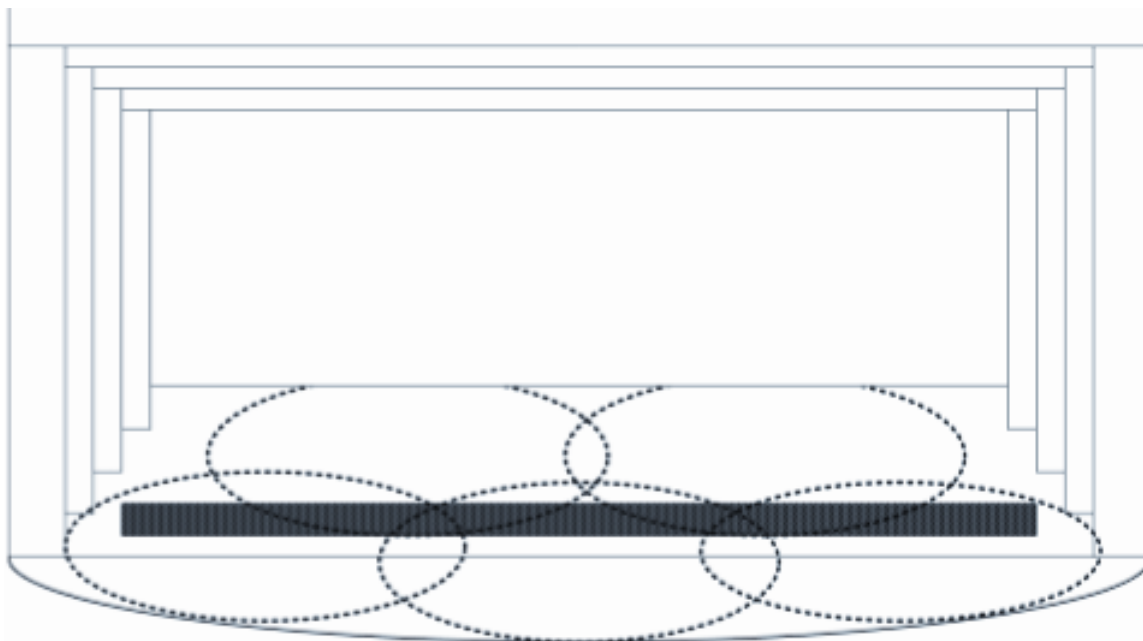

- CONTRACT RIDER: THE SHANGRI-LA CHINESE ACROBATS Revised 03/15/2010

- **1st Electric**

Par wash: The ceramic is set to a horizontal (*stage-right/stage-left*) wash. The acrobats' tumbling mat is set out midway between the 1st and 2nd electrics running from stage right to stage left (see *Diagram on Page 3*). The pars/fresnels are focused so that the hot spot of the beam is on a person standing on the mat.

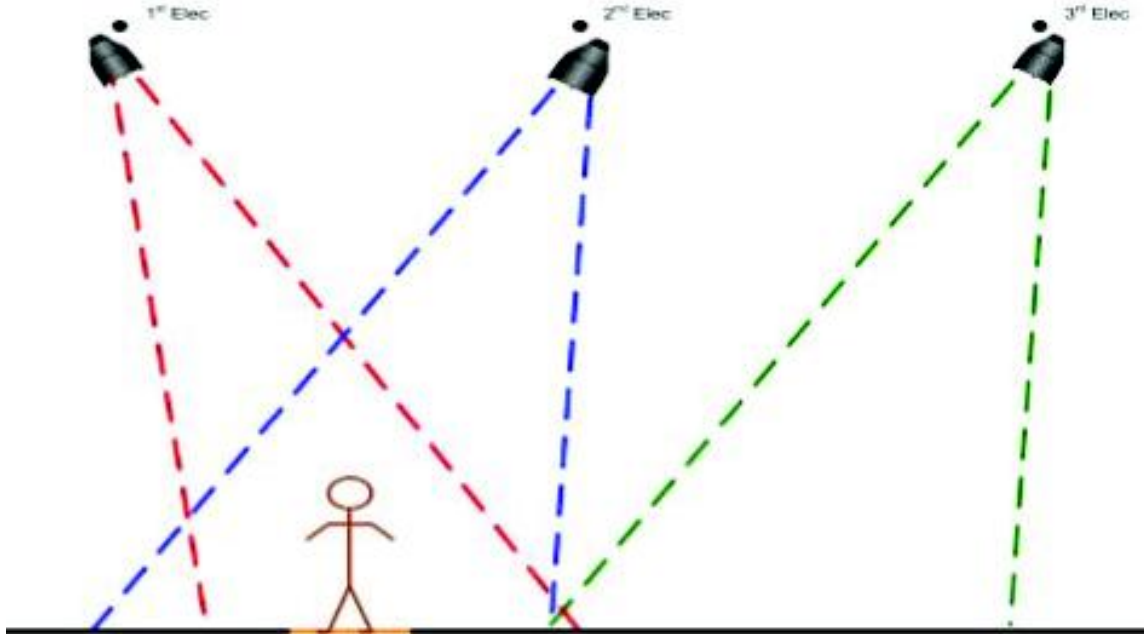

Pipe ends: The pipe ends focus directly under the electric, and wash across the stage, starting at center and going off stage away from the instrument. They should be shuttered off the proscenium, vertically, and be open up-stage.

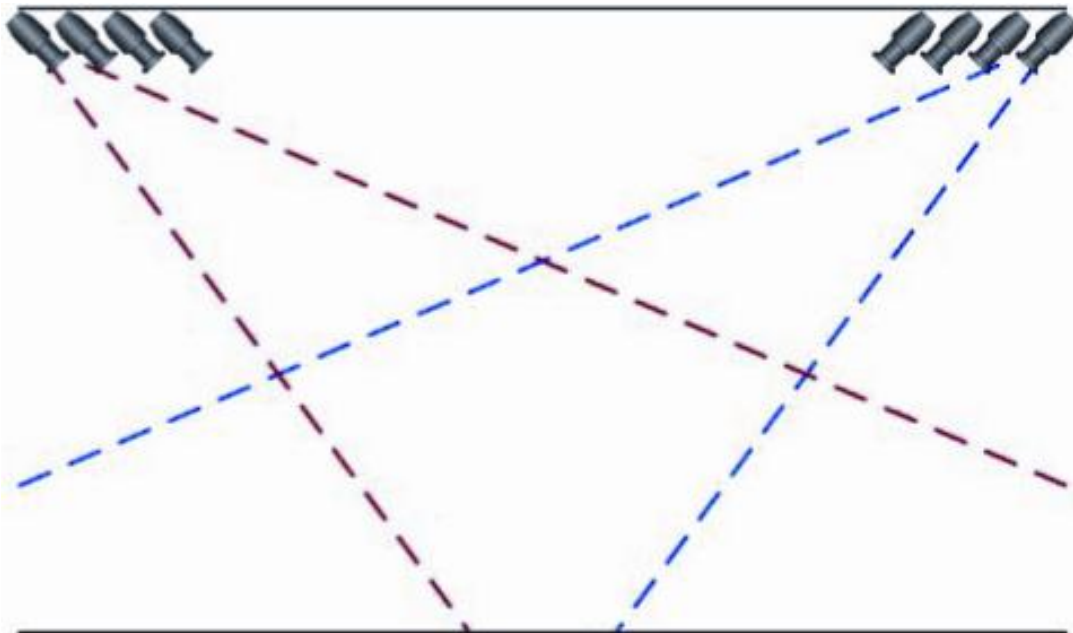



CONTRACT RIDER: THE SHANGRI-LA CHINESE ACROBATS Revised 03/15/2010

- **2nd Electric**

Par wash: The ceramic is set to a horizontal (*stage-right/stage-left*) wash. These pars/fresnels are focused so that the hot spot of the beam is on the tumbling mat. (See figure on page, 4).

Pipe ends: These pipe ends also focus directly under the electric, wash across the stage starting at center, and should have the shutters open unless they wash past the proscenium, vertically, or onto the cyc. (See figure on page 4).

- **3rd Electric**

Par wash: The ceramic is set to a horizontal (*stage-right/stage-left*) wash. The pars/fresnels are focused so that the hot spot of the beam is between the 2nd and 3rd electrics. (See figures on page 4).

Pipe ends: These pipe ends also focus directly under the electric and wash across the stage starting at center, and should be shuttered off the cyc, vertically. (See figures on page 4).

- **Cyclorama**

Each venue usually has its own cyclorama lighting, and this will suffice for our production. Cyclorama colors should be **primary red, blue, and green**. A **bright, full** cyclorama is very important to the show and suggestions for lighting the cyclorama are shown on the attached lighting plot.

4. FOLLOW SPOTS

Two strong follow spots of equal wattage and working color boomerangs are required. Please make sure they have a flat field as bright as possible and are set to a **soft edge**. Spot colors used during the presentation are: **Rx33** (*frame 1*), **Rx64** (*frame 2*), **Rx132** (*frame 3*), and **No Color**.

5. PATCHING

The table on the following page shows the channels the company will use to build the cues for the show. However, programming the venue's console with these channels will facilitate focus and allow the use of the venue's console for the presentation. How you 'two-fer' the instruments is up to you, as long as the channels stay "as-is" on the patch sheet.

The Shangri-La Chinese Acrobats[®] plot uses 31 channels. If the venue's console has less than 31 channels, please contact the Production Office or the Technical Director for alternatives. Any changes, however, should be made to the venue's console channels **ONLY** and not to the dimmers or the patch sheet! **It is most important that the patch sheet as submitted is entirely accurate as there will be minimal time for trouble-shooting during load-in.**



CONTRACT RIDER: THE SHANGRI-LA CHINESE ACROBATS Revised 03/15/2010

The Shangri-La Chinese Acrobats® Channel Patch Sheet:

Channel	Electric	Color	Focus
Channel 01:	Front of House	Rx33	Down Stage wash
Channel 02:	Front of House	Rx33	Up Stage wash
Channel 03:	Front of House	Rx26	Down Stage wash
Channel 04:	Front of House	Rx26	Up Stage wash
Channel 05:	Front of House	Rx67	Down Stage wash
Channel 06:	Front of House	Rx67	Up Stage wash
Channel 07:	Front of House	Rx12	Down Stage wash
Channel 08:	Front of House	Rx12	Up Stage wash
Channel 09:	Pipe Ends	Rx33	All 3 Electrics
Channel 10:	Pipe Ends	Rx26	All 3 Electrics
Channel 11:	Pipe Ends	Rx67	All 3 Electrics
Channel 12:	Pipe Ends	Rx12	All 3 Electrics
Channel 13:	1st Electric	Rx26	Par/Fresnel Wash
Channel 14:	1st Electric	Rx67	Par/Fresnel Wash
Channel 15:	1st Electric	Rx12	Par/Fresnel Wash
Channel 16:	2nd Electric	Rx26	Par/Fresnel Wash
Channel 17:	2nd Electric	Rx67	Par/Fresnel Wash
Channel 18:	2nd Electric	Rx12	Par/Fresnel Wash
Channel 19:	3rd Electric	Rx26	Par/Fresnel Wash
Channel 20:	3rd Electric	Rx67	Par/Fresnel Wash
Channel 21:	3rd Electric	Rx12	Par/Fresnel Wash
Channel 22:	1st Electric	N/C	Cross Special
Channel 23:	1st Electric	N/C	Center Special
Channel 24:	2nd Electric	N/C	Center Special
Channel 25:	2nd Electric	N/C	Up Stage Special
Channel 26:	2nd Electric	N/C	FOH Special
Channel 27:	Cyc Lights	Red	Cyclorama
Channel 28:	Cyc Lights	Blue	Cyclorama
Channel 29:	Cyc Lights	Green	Cyclorama
Channel 30:	House Lights	N/C	House
Channel 31:	Curtain Warmers	N/C	Stage Left & Stage Right



CONTRACT RIDER: THE SHANGRI-LA CHINESE ACROBATS Revised 03/15/2010

D. RIGGING

The Shangri-La Chinese Acrobats® rigging is obviously very important, and is sometimes a matter of safety. For this reason, the performers themselves shall have final say about any rig that supports their weight. The Shangri-La Chinese Acrobats® require as much of the fly loft as possible to put on the best possible performance. The company will work around whatever hangs permanently in the loft of the venue, but the company does ask that the loft be stripped of any non-essential drops or other obstructions that might limit availability of line-sets or space in the fly loft. If you do not have a fly loft, the performance can still be done. Please contact the Production Office for staging alternatives in this case. The Shangri-La Chinese Acrobats® features many different acts in each full performance. Only a few actually require rigging, and this document will go into each one in detail. Actual rigging requirements will vary, depending on your program and the capabilities in your venue.

- **Electrics:**

Pipes should be trimmed as close to 26' as possible.

- **Borders:**

Borders need to be downstage and as close to each electric as possible. The trims should be set to just barely hide the lighting pipes.

- **Legs:**

Furthest downstage legs should be tied approximately 19' from center. Subsequent legs should be tied further upstage in 1' increments or as needed for sight lines. Leg pipes need to be trimmed to at least 26'. Legs will need to be extended down from the pipe if shorter than 26'. In smaller theatres, check with the Production Office or our Technical Director to adjust trim height.

- **Poles:**

Depending on grid height, a pipe hung directly above the poles will be used to fly them out. Guide wires are strung to 4 points off stage. If secure points are not available, permission to drill 4 small holes for eyebolt lags is requested. Please inform the Production Office or the Technical Director as soon as possible if lagging is not permitted on your stage floor. This act may NOT be part of your program and this will be advanced by the Production Office.

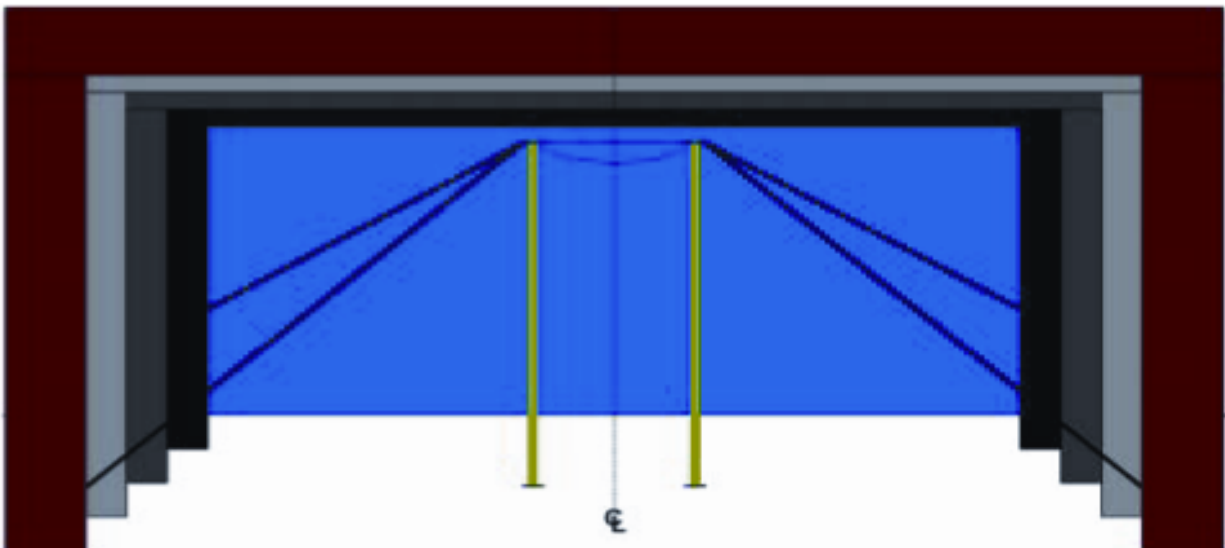

- **Straps:**

No weight is necessary on the arbor for these straps, but, when in place, they must support the weight of 6 acrobats (*approximately 1000 lbs.*). Thus, a cable will be run from the arbor and anchored to the fly rail allowing the pipe to fly out, supporting the weight when brought to trim. The strap apparatus and cable is provided by the company. A backup cable supplied by the venue is suggested for emergencies. This act may NOT be part of your program. The Production Office will advise if this act is your program in advance.

- **Travelers:**

A rear black curtain between the cyc and the cyc lights/ground row is the ideal for this show. The best look is a full black traveler but a bounce drop or a black scrim may also be used. A mid-stage traveler should be hung just upstage of the 2nd Electric, if available, and must be able to be opened and closed in either the lateral or guillotine fashion so venue technicians can ring the traveler in and out when needed for the production.

E. AUDIO

The production carries digitally pre-recorded music on CD which will be played using the presenter's house sound system, house soundboard, and mixers. The production does NOT travel with their own soundboard. One microphone with an "on/off" switch and two side fill monitors are required. The microphone is for show announcements as necessary and should be positioned with our stage manager. The side fill monitors should be placed downstage left and right so the performers can hear their musical cues. Please note that this production does not carry amplifiers or speakers. It is the responsibility of the presenter to ensure that the theatre's sound system is of sufficient quality to allow the audience to hear and enjoy the show.

Headset communications will be required between the following personnel and areas:

1. Lighting Technician
2. Sound Technician
3. Stage Right
4. Stage Left
5. Fly Rail (As available.)
6. Follow spot operator #1 (As available.)
7. Follow spot operator #2 (As available.)

The performance cannot be done without this communication system!

F. SUPPLIES

- **Consumables**

For **EACH** PERFORMANCE, the presenter must provide, at their cost, the following:

- Two (2) new rolls of black Gaffer's tape.
- Ten (10) solid, regular household, red clay bricks for the Kung-Fu Act. No concrete bricks!
(The Kung-Fu Act may NOT be part of your program, and the bricks will be advanced if required.)
- Twelve (12) Stemmed Flowers (Assorted colors, **please NO WHITE flowers.**)

Please note: The 12 stemmed flowers are optional. These flowers will be given to the company during the curtain call, and the company will throw them to the audience as a "farewell" gesture. The technical director will explain the logistics upon arrival. What type of flower is at the discretion of the presenter, but please note that **white flowers of any kind are NOT acceptable.** We recommend red carnations, as red is a lucky color in Chinese tradition, and these flowers are the least crumbly, for ease of clean-up after the show.

- **Miscellaneous**

The following items should be available backstage to the company during each performance:

PLEASE NOTE: The stage **MUST** be wet mopped and the performer's carpet **MUST** be vacuumed **BY VENUE STAFF** prior to each performance **AND** at intermission! This is for the safety of the performers and helps to keep their costumes clean during the performance so **PLEASE** make sure that this is done at the appropriate intervals at each performance!

- One (1) Dry Mop.
- One (1) Wet Mop with Bucket.
- One (1) 8' Ladder.
- One (1) Small table with light and chair (for Stage Manager, if no production office is available.)
- Four (4) BATH SIZE Towels, or Stage Rags. (For use in mopping up moisture off the stage.)
- Twelve (12) Clean Hand-Size Towels, for the performer's personal use, **TO BE PLACED IN THE DRESSING ROOMS READY FOR THE GROUP'S ARRIVAL.**
- One (1) Vacuum (To vacuum our tumbling mats as necessary.)
- Two (2) 8' Property Tables situated safely near the stage entrances and exits upstage left and upstage right.

G. SPECIAL EFFECTS

- **Contortion Act:**

2 or 3 women carry out candelabras to 1 woman on a platform. The woman then balances the candelabras using her head, feet, and hands. The act uses 6 candelabras, each with about 7 candles, for a total of about 35 - 42 candles used at once, depending on the individual performing the act. Either smoke-less oil or votive candles are implemented in this act. The performers can use colored water and electric candles in lieu of fire in this act.



Example of Contortionist Act



Example of Costumes

Nose Balancing:

2 women carry out candles and a lamp to 1 woman who balances them on her nose using a series of small trays stacked one atop the other. The act has a total of 13 candles and 1 lamp. Either smoke-less oil or votive candles are implemented in this act. The performers can use colored water and electric candles in lieu of fire in this act.



Ex. of Nose Balancing Act



Ex. of Oil Used in These Acts



Ex. of Candelabras in These Acts

As indicated above, if fire is not allowed on your stage, please notify the production office or our technical director as soon as possible, and colored water with electric candles will be substituted to the same effect.

H. PERFORMER/CREW SERVICES

This agreement requires the presenter to provide hospitality for approximately 15 members of The Shangri-La Chinese Acrobats® during their load-in and the performance(s). Additionally, a hot meal is required if the company is performing more than one show in one day. In some cases, load-in will take place the day prior to the performance(s) and hospitality will be required for both days. Hospitality items should be pre-set in time for the production's arrival. All items should remain left out for the company. Not everyone will enjoy their food at once, but will eat when they have time throughout their stay at your venue. If local regulations require the changing out of fresh food items, please REPLACE those items, however, the company MUST be provided with sufficient food and beverages for the duration of their time at your venue! Please remember to provide enough food, drinks, plates, napkins, forks, spoons, knives, cups, and chop sticks for approximately 15 people. Quantities below are intended to allow company members to have more than one serving of some items.

- **Morning Provisions:**

(To be provided for all morning arrivals and load-ins, before and including Noon):

Large Pot of Coffee (enough for 5 people, not everyone in the Company drinks coffee.)
 Large Pot of Hot Water (enough for 30 drinks.)
 Large package of Lipton Tea Bags, Variety of Flavors (enough for 30 drinks, some will have 2 or more servings.)
 Cream, Real Sugar, Cups, Stirrers and Spoons (enough for 30 drinks, some will have 2 or more servings.)
 Assortment of Coke Classic, Diet Coke, or other sodas (25 cans, some will have 2 or more servings.)
 Assortment of Fruit Juices (orange, apple, cranberry, etc.) (25 cans/boxes, some will have 2 or more servings.)
 Gatorade, Powerade, or other Sports Drink (12 individual sized bottles or 1 case, not everyone will have some.)
 Bottled Water (30 bottles, some will have 2 or more servings.)
 Whole Milk (2 Gallons.)
 Bagels and Cream Cheese (total 12 pieces.)
 Dry Cereal (3 Large Boxes, Suggested Varieties: Rice Krispies, Frosted Flakes, Granola, Total or Shredded Wheat.)
 Doughnuts (only about 6 pieces, mainly for the Western crew.)
 Fruit (apples, oranges, bananas, etc.) (30 pieces total, some will have 2 or more servings.)
 Assortment of Chips (In either individual combination packs, or 4 large bags, some will have 2 or more servings.)

- **Afternoon & Evening Performance Provisions: (To be provided for all afternoon arrivals, load-ins, and for all performances. These items should be provided IN ADDITION to the Morning Provisions above, IF the performers arrive at or before Noon, and no hot meal is being provided. Please contact the production office to set a serving time for these items!)**

Large Pot of Coffee (enough for 5-7 people, not everyone in the Company drinks coffee.)
 Large Pot of Hot Water (enough for 30 drinks, some will have 2 or more servings.)
 Large package Lipton Tea Bags, Variety of Flavors (enough for 30 drinks, some will have 2 or more servings.)
 Cream, Real Sugar, Cups, Stirrers, and Spoons (enough for 30 drinks, some will have 2 or more servings.)
 Assortment of Coke Classic, Diet Coke, or other sodas (25 cans, some will have 2 or more servings.)
 Assortment of Fruit Juices (orange, apple, cranberry, etc.) (25 cans, some will have 2 or more servings.)
 Gatorade, Powerade, or other Sports Drink (12 small bottles or 1 case, not everyone will have some.)
 Bottled Water (30 bottles, some will have 2 or more servings.)
 Whole Milk (2 Gallons)
 Deli Meats Tray for 15 people (1 Large Tray of sliced Chicken, Beef, and Turkey...No Ham, Please!)
 Small Cheese Tray (1 Small Tray, enough for about 5-7 people only. Not all company members eat cheese.)
 Garnish Tray for 15 people (1 Medium Tray, to include lettuce, sliced tomato, sliced pickles, and sliced onions.)
 Vegetable Tray for 15 people (1 Large Tray, with hummus dip or salad dressing to accompany the vegetables.)
 Condiments for Sandwich-Making (To include mayonnaise, mustard, and butter.)
 Bread (Enough for about 30 sandwiches, some will have 2 or more servings.)
 Crackers (2 Boxes per Deli/Cheese Tray ~ 4 Boxes Total, some will have 2 or more servings.)
 Fruit (Apples, Oranges, Bananas, etc.) (30 pieces total, some will have 2 or more servings.)
 Assortment of Chips (In individual combination packs, or 4 large bags, some will have 2 or more servings.)

- **Hot Chinese Meal: (Meals are greatly appreciated! If you have only one show and wish to provide a meal for the Group, we welcome you to do so. For those with more than one show on one day, meals are required. All meal times must be pre-arranged with the Production Office. Please note that the meal does not have to follow this menu precisely. Please contact the production office with any questions. Follows the SUGGESTED MENU for the meal, and please provide enough food for 15 people.)**

General Tso's Chicken	Beef with Broccoli
Pork Chow Mein	Vegetable Stir Fry dish (Vegetarian)
Steamed White Rice	One or Two Appetizers (spare ribs, pot stickers, egg rolls, etc.)

A Chinese Family Dinner or a Regional American Meal is also acceptable for the meal you provide. All meals must include at least one vegetarian dish for those in the company who are vegetarians (usually about 5-6 people in each Group). Please contact the Production Office with questions on the meals and THANK YOU!*



CONTRACT RIDER: THE SHANGRI-LA CHINESE ACROBATS Revised 03/15/2010

I. DRESSING ROOMS

Two large (*approximately eight people per room*) chorus-type dressing rooms are required for the ladies and men in the company. One star dressing room with a working telephone and access to outside lines (*for our Technical Director to use as a production office*) will also be required. These rooms **MUST** be adequately lighted, and properly heated or cooled. They should be near hot and cold running water and have easy access to toilet facilities. Dressing rooms should be cleaned prior to the performers' arrival. No one except production personnel should be allowed in these dressing rooms during the production's stay. **PLEASE SEE ITEM P ON PAGE 12!**

J. QUICK CHANGE AREAS

In the event that the dressing rooms are too far from the stage, two quick-change areas will be required backstage. Each should contain a full-length mirror, lights, table, and chairs. The technical director will advise you if these are required in your theatre prior to the company's arrival.

K. PARKING

After load-in, the production will require a total of TWO PARKING SPACES: One parking spaces for one 15-passenger van and one tow-behind trailer at or as near as possible to the theatre loading dock. If there is insufficient space at the theatre, presenters are required to make other arrangements in advance. If a commercial parking lot is used, please advise the parking lot personnel, in advance, of the arrival and departure times of the company. Payment of any parking fees are the expense of the presenter and must be taken care of prior to the group's arrival. If the presenter is providing hotel accommodations for the group, then the presenter is also responsible for any hotel parking fees. Under no circumstances will the production pay for parking either at the venue or at a hotel provided by the presenter.

L. MERCHANDISE

The Shangri-La Chinese Acrobats® may elect to sell merchandise at each performance. The production office will notify if the company are selling merchandise. The company usually sells their own merchandise and will not require assistance from house personnel. Please be sure to arrange **IN ADVANCE OF THE COMPANY'S ARRIVAL** one 6' – 8' table, draped in a white, red or black table cloth in a prominent place in your lobby for the sale of merchandise. If available, a pipe and drape display area behind the table would be appreciated. Also, two chairs behind the table are requested for our merchandise seller. If the presenter does not indicate the amount of commission required during the show advance, then it is agreed that no commission whatsoever will be payable to either the presenter or the venue.

M. COMPLIMENTARY TICKETS

The Presenter shall hold twelve (12) complimentary tickets to each performance for use by either the producers or the agents of The Shangri-La Chinese Acrobats®. Tickets not requested and set aside for the producer or agent within 24 hours of the performances may be sold.

N. SELLING THE PIT

The Shangri-La Chinese Acrobats® are choreographed to play only down to the plaster line. If you have a pit downstage of the main curtain, it should be seated and sold as prime seats. This will not only add income to the venue, but it will also set the acts closer to the audience and provide a more exciting performance.

O. EMERGENCY INFORMATION

The presenter should post at the stage manager's desk the telephone numbers of the police, fire department, and any other emergency service provided for your theatre's area. Additionally, it is helpful if the presenter will provide the names, addresses, and telephone numbers of a recommended dentist, doctor and a twenty-four hour hospital and/or clinic which the company may use while in residence.



CONTRACT RIDER: THE SHANGRI-LA CHINESE ACROBATS Revised 03/15/2010

P. MEDIA INTERVIEWS & CONTACTS/CLOSED LOAD-IN

IAI Presentations, Inc. and The Shangri-La Chinese Acrobats® endeavor to create the most memorable and exciting theatrical experience possible at each venue. **Because of the technical nature of the show, the company's crew and artists are very busy setting up and preparing for the performance(s) from the time they arrive at the venue until curtain time. Therefore, IAI Presentations, Inc. requests that the load-ins and load-outs be closed to the public and the media, and that no photographing or videotaping of the load-in or load-out be permitted. Under NO circumstances, shall there be any photographers, any unauthorized videotaping, or 'surprise' media interviews requested of the artists or crew during the load-in or load-out.** It is the responsibility of the presenter and their staff to ensure that backstage areas, including dressing rooms and green rooms, are secured at all times while the Company is at the venue. **UNDER NO CIRCUMSTANCES WILL MEDIA BE ALLOWED BACKSTAGE AT ANY TIME DURING THE PERFORMERS TIME AT THE VENUE. ABSOLUTELY NO VIDEO-TAPING OR PHOTOGRAPHS OF LOAD-IN, LOAD-OUT OR PERFORMANCES WILL BE ALLOWED FROM ANY BACKSTAGE AREAS.**

When time allows, media interviews may be granted by IAI Presentation's production office, but any such interview or media presence at the venue must be pre-approved by the management by contacting the Production Office. **This applies to any and all TV news taping, archival tapings, and archival or media photographs of our performance.**

*****NO MEDIA WILL BE GIVEN INTERVIEWS OR ACCESS TO THE COMPANY WITHOUT PRE-APPROVAL FROM THE PRODUCTION OFFICE.*****

For advance clearance on media interviews, please contact Ms. Cynthia Dike-Hughes at IAI Presentations' production office at (805) 474-8422, ext. 12 or by e-mail at cynthia@iaipresentations.com. A minimum advance notice of 24 hours is required.

*****NO FLASH PHOTOGRAPHY IS PERMITTED DURING OUR PERFORMANCE(S), AS IT MAY BE DANGEROUS TO THE PERFORMERS.*****

Q. FEDERAL, STATE, AND CITY TAXES

Presenter shall pay and hold harmless the artists, agents, and production company from any State or City taxes, fees, dues and the like relating to the engagement herein and the sums stated herein and payable to the artists, agent or production company shall be free of such taxes, dues, and the like. This provision may not be amended, deleted, or cancelled without written agreement by the production company.

Withholding Tax Under Revenue Code Section 1441

The artists are performing under the aegis of a U.S. corporation, International Asia, Inc. and are treated by International Asia, Inc. as employees for U.S. tax purposes. International Asia, Inc. is unrelated to the performers being neither owned nor controlled by the performers. Under these circumstances, there is no need for any U.S. person making payments to, or for the benefit of, International Asia, Inc. to withhold U.S. income taxes under I.R.C.â 1441 other than to ask for and receive a W-9 from this corporation. W-9's are also required when payments are made to either SRO Artists, Inc or IAI Presentations, Inc. If you have any questions please contact Cecile.Glunt@irs.gov or Anthony.H.Kite@irs.gov, the Internal Revenue Service's CWA Program Specialists.



CONTRACT RIDER: THE SHANGRI-LA CHINESE ACROBATS Revised 03/15/2010

R. MISCELLANEOUS and CONTACT INFORMATION

Your Technical Director may obtain additional information by calling IAI Presentations, Inc. in California. We are aware that no two theatres are alike, and we are here to assist you in keeping your technical costs to a minimum. THE SHANGRI-LA CHINESE ACROBATS® can adapt to smaller stages and are extremely flexible. They are consummate professionals and can overcome virtually any technical problems and still give an exciting and satisfying performance.

Our offices and our Technical Director will contact you and your Technical Director to confirm the details of your performance and your technical specifications prior to the company's arrival at your theatre. We will answer questions, set load-in times, and confirm Group arrival times during the show advance. If you have questions regarding the suitability of your playing space, or are unable to provide items listed in this rider, refer these information to:

Production Office Contact Information:

Mr. Don Hughes, President, don@iaipresentations.com, Ext. 14
Mrs. Cynthia Dike-Hughes, Vice President, cynthia@iaipresentations.com, Ext. 12
Ms. Katie Bates, Production Associate, katie@iaipresentations.com, Ext. 20
Mr. Graham Haworth, Production Associate, graham@iaipresentations.com, Ext. 10
IAI Presentations, Inc.
P.O. Box 4, Pismo Beach, CA 93448
Telephone: (805) 474-8422
Fax: (805) 474-8426

